

LARSON · JUHL®

TRIBECA

BLACK & WHITE REDEFINED

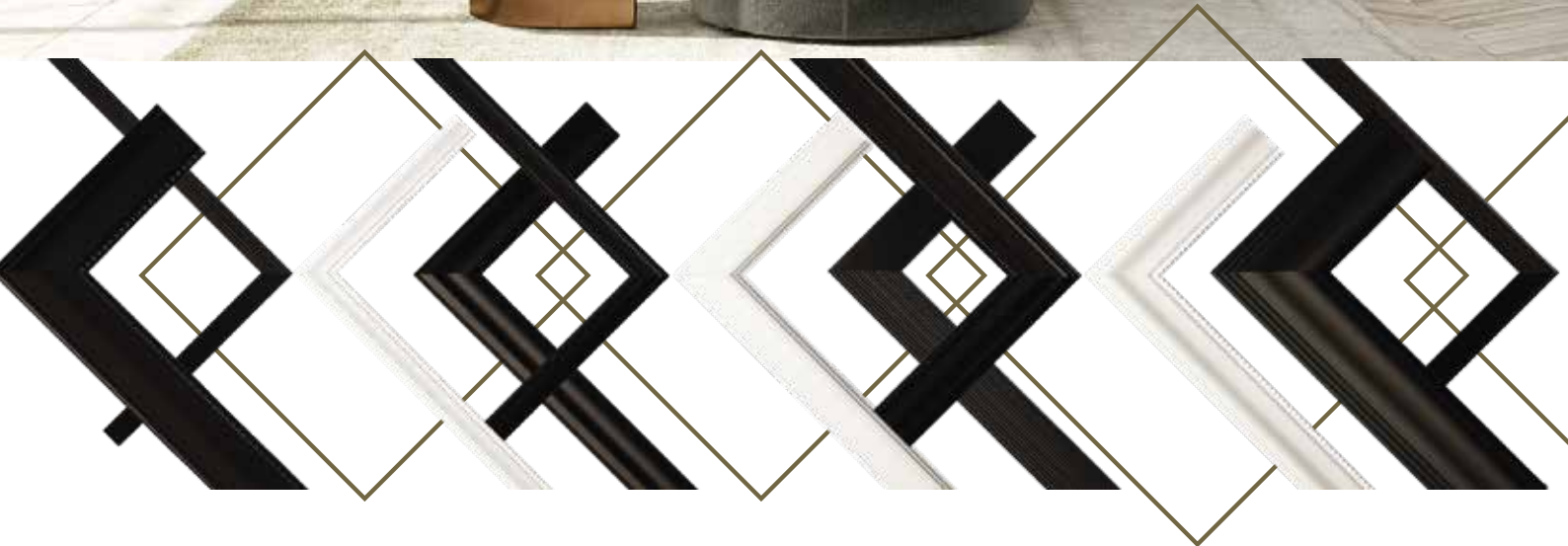

LARSON · JUHL®

www.larsonjuhl.com.au

TRIBECA

BLACK & WHITE REDEFINED

Introducing the Tribeca Moulding Collection.

Redefine the essence of black and white profiles with Tribeca, where every frame tells a story of subtle classic design.

The embodiment of timeless allure and modern finesse, where the grace of Art Deco curves and lines intertwine. Enveloped in a classic matt black and white palette, adorned with scoop, reverse scoop, and square profiles, this collection unveils a new realm of creative expression for picture framers. With Tribeca, framing transcends mere presentation; it becomes an art that bridges eras, encapsulating both history and innovation within each frame. From minimalist settings to eclectic interiors, the collection seamlessly complements diverse styles, adding an understated touch of elegance or a whisper of opulence.

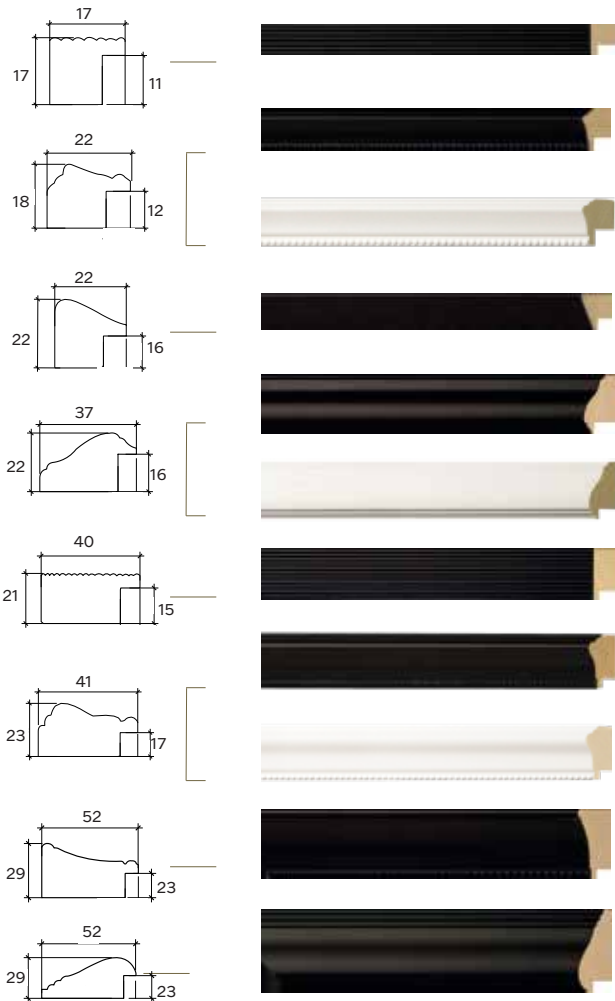

- 200285 17x17x11 Matt Black
- 230285 18x22x12 Matt Black
- 230286 18x22x12 Matt White
- 212285 22x22x16 Matt Black
- 350285 22x37x16 Matt Black
- 350286 22x37x16 Matt White
- 370285 21x40x15 Matt Black
- 390285 23x41x17 Matt Black
- 390286 23x41x17 Matt White
- 542285 29x52x23 Matt Black
- 552285 29x52x23 Matt Black